



# CBE Series Chef Base

**MODEL #178CBE52HC**

## CABINET CONSTRUCTION

Sturdy and corrosion-resistant design features both a 430 type stainless steel exterior and interior.

Foamed-in-place CFC- and HCFC-free polyurethane insulation enhances the structural integrity of the cabinet and promotes energy efficiency.

1¾" thick stainless steel top surface features raised marine edges to help contain spills and leaks. Accommodates up to 990 lb. of weight.

## REFRIGERATION SYSTEM

Environmentally safe R290 refrigerant. Rear-mounted condensing unit positioned for easy maintenance.

## DRAWERS

2 refrigerated drawers can each accommodate 3 full size, 4" deep food pans.

## MODEL FEATURES

Digital temperature controller makes operation simple.

Auto defrost feature for intuitive cleaning and maintenance.

Outfitted with (4) 4" casters for mobility prior to cleaning and servicing tasks.

PROJECT: \_\_\_\_\_

MODEL: \_\_\_\_\_ SERIAL#: \_\_\_\_\_

ITEM #: \_\_\_\_\_ QUANTITY: \_\_\_\_\_

APPROVAL: \_\_\_\_\_ DATE: \_\_\_\_\_

## CBE SERIES - CHEF BASE

A practical storage and productivity solution for busy kitchens.

## SPECIAL FEATURES

- 1¾" thick stainless steel top with marine edges to contain spills
- Top accommodates up to 990 lb. of weight
- 2 refrigerated drawers for food storage
- Digital temperature controls hold at 33-40°F
- Temperature display for easy monitoring
- Foamed-in-place polyurethane insulation
- Environmentally-friendly R290 refrigerant
- 430 type stainless steel interior and exterior
- Auto defrost feature
- ½ hp compressor



## WARRANTY

RESIDENTIAL: Avantco assumes no liability for parts or labor coverage for component failure, factory defect or any other damages for units installed in non-commercial foodservice or residential applications.



Parts & Labor



Compressor



★ Conforms to UL & NSF-7 Standards

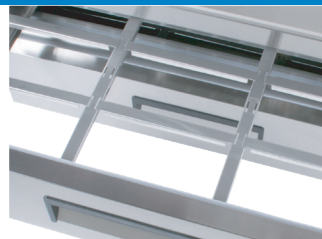

## TECHNICAL DATA

### Dimensions

Exterior Dimensions	51 $\frac{1}{8}$ "W x 32 $\frac{1}{8}$ "D x 25 $\frac{7}{8}$ "H
Interior Dimensions	40 $\frac{1}{8}$ "W x 27 $\frac{1}{2}$ "D x 16 $\frac{1}{2}$ "H
Number of Drawers	2
4" Deep Pan Capacity (Per Drawer)	(3) Full
Top Thickness	1 $\frac{3}{4}$ "
Net Volume	10.5 cu. ft.
Net Weight	233 lb.
Gross Weight	279 lb.
Packing Dimensions	54 $\frac{1}{2}$ "W x 35"D x 28 $\frac{1}{2}$ "H

### Cooling

Temperature Range	33°F - 40°F
Refrigerant	R290
Max. Ambient Temperature	100°F
Defrosting	Automatic
Temperature Display	Yes
Temperature Controller	Digital
Horsepower	1/6

### Construction

Exterior Material	Type 430 Stainless Steel
Top Material	Type 430 Stainless Steel
Insulation Material	Foamed-in-place Polyurethane
Top Edge	Marine
Weight Capacity	990 lb.
Drawer Capacity	132 lb.

### Electrical

Voltage	115
Amps	3.5
Hz	60
Phase	1
Plug Type	NEMA 5-15P
Electrical Cord Length	84"

## PLAN VIEW

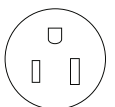
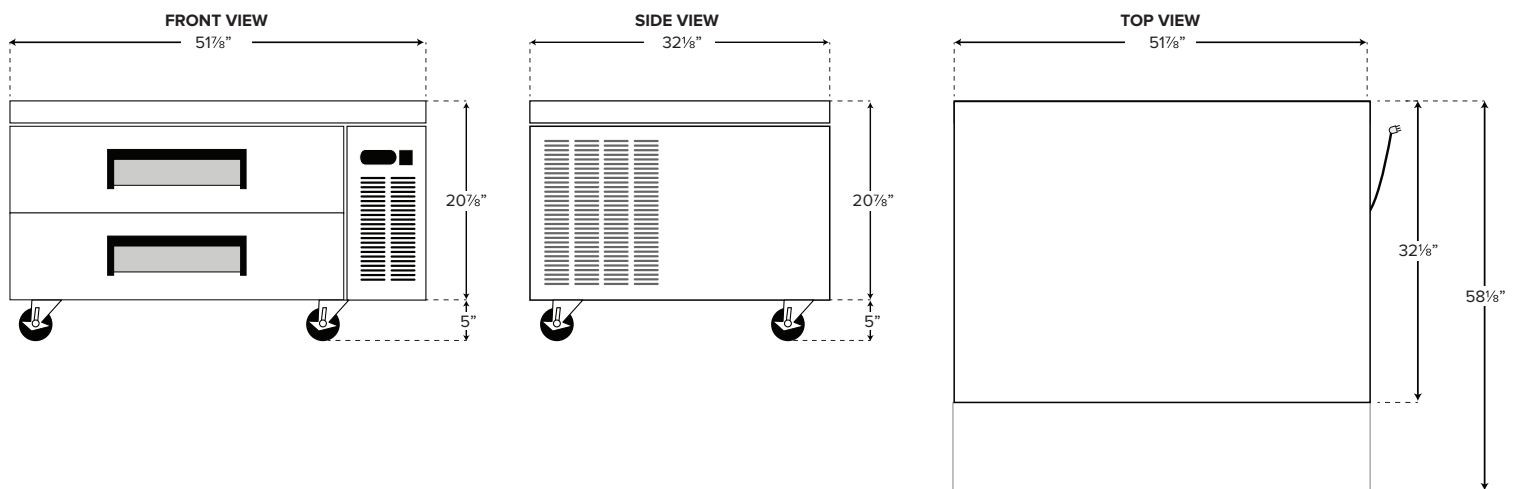

NEMA 5-15P