

BATIDORAS PLANETARIAS



PPM-10



PPM-20



PPM-30

Características:

- Batidora planetaria de uso rudo.
- Tazón de a.inox., con elevador.
- Paleta, globo y gancho.
- Rejilla de seguridad.
- Engranaje de tres velocidades.
- Temporizador de 30 minutos.
- Interruptor de seguridad.
- 1 cable de 1.8 m, con clavija.
- 4 patas de goma antideslizantes.
- 1 fase.



• INFORMACIÓN TÉCNICA:

MODELO	MOTOR	V-I	V-II	V-III	VOLTAJE	FRENTE	FONDO	ALTO	PESO
PPM-10	1 HP	108 RPM	195 RPM	355 RPM	127V/60Hz	0.393 m	0.393 m	0.609 m	36 Kg
PPM-20	1.5 HP	106 RPM	180 RPM	367 RPM	127V/60Hz	0.552 m	0.533 m	0.812 m	95 Kg
PPM-30	2 HP	91 RPM	166 RPM	282 RPM	127V/60Hz	0.584 m	0.609 m	1.168 m	169 Kg

• VISTA FRONTAL

F R E N T E

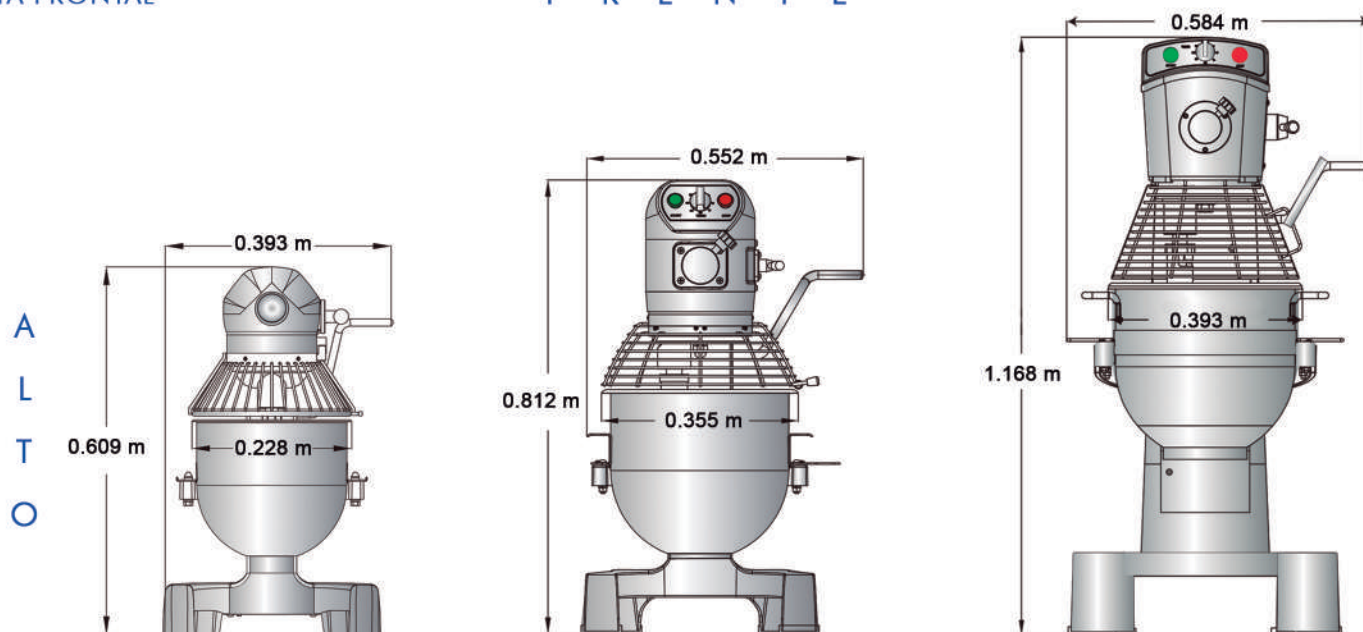

• VISTA LATERAL

F O N D O

