

PROJECT: \_\_\_\_\_

MODEL: \_\_\_\_\_ SERIAL#: \_\_\_\_\_

ITEM #: \_\_\_\_\_ QUANTITY: \_\_\_\_\_

APPROVAL: \_\_\_\_\_ DATE: \_\_\_\_\_



# 14 Qt. Round Countertop Food/Soup Kettle Warmer

## ITEM NUMBER

#177S600

## SPECIAL FEATURES

- Great for keeping soups and sauces at perfect temperature with fully adjustable control
- Includes hinged lid, ring, 14 qt. stainless steel inset, and 14 popular soup and stew labels
- Designed with a removable and dishwasher safe lid and inset for easy cleaning
- Cool-touch handle and hinged lid design for safety and ladle storage when not in use
- 120V, 600W



TOP

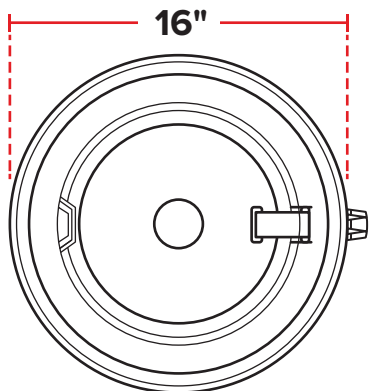

SIDE

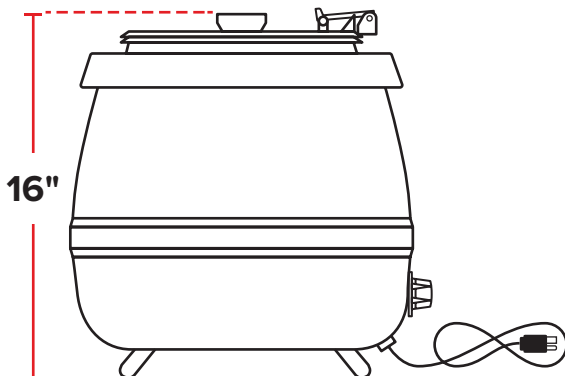

## TECHNICAL DATA

Height	16"
Diameter	16"
Voltage	120V
Wattage	600W
Hertz	60Hz
Amps	5.5 Amps
Capacity	14 qt.
Control Type	Dial
Temperature Range	105-195°F
Inset Material	Stainless Steel
Exterior Color	Black



**5-15P**