



# 11 Qt. Round Countertop Food/Soup Kettle Warmer

## ITEM NUMBER

#177W800

## SPECIAL FEATURES

- Great for any buffet or concession stand that needs to hold soups & sauces at perfect temperatures
- Manual control knob makes temperature adjustment easy and reliable with 6 heat control settings
- Durable stainless steel inset and interior lining are removable and dishwasher safe for easy clean up
- Cool-touch handle and hinged lid design for safety and ladle storage when not in use
- 120V, 800W allows for a more efficient and faster heating time versus traditional warmers



TOP

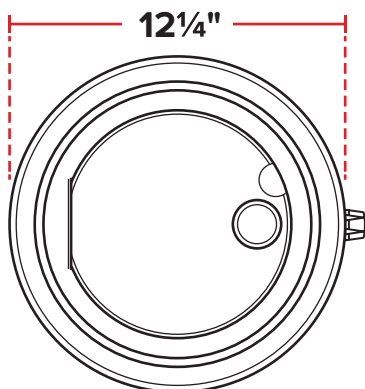

SIDE 13 3/4"

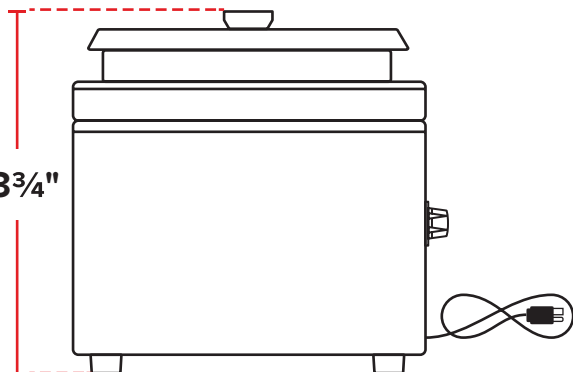

## TECHNICAL DATA

Height	13 <sup>3</sup> / <sub>4</sub> "
Diameter	12 <sup>1</sup> / <sub>4</sub> "
Voltage	120V
Wattage	800W
Hertz	60Hz
Amps	6.7 Amps
Capacity	11 qt.
Control Type	Dial
Temperature Range	105-195°F
Inset Material	Stainless Steel
Exterior Color	Stainless Steel



5-15P