



CONGELADORES HORIZONTALES CURVOS DE PUERTA DE CRISTAL



• MMF9110



Características:

- Congelador horizontal curvo, con 2 puertas de cristal.
- Ideal para conservar helados o alimentos congelados.
- Gabinete en acero con esmalte blanco.
- Interior de aluminio blanco aprobado por NSF.
- Respaldo posterior externo en a.alum.
- 2 puertas corredizas de cristal templado.
- Cerradura.
- Cestos de alambre con recubrimiento blanco.
- Drenaje de descongelación para facilitar la limpieza.
- Aislamiento de espuma 3" de espesor.
- Iluminación LED interna.
- 1 condensador dinámico.
- 1 clavija para contacto NEMA-5-15.
- Rango de temperatura de -18 a -22°C.
- 1 compresor con refrigerante ecológico.
- 4 ruedas 50 mm.
- Certificados NSF, UL, CSA & NOM.



• MMF9113



• INFORMACIÓN TÉCNICA:

MODELO	CAP. PIES ³	CESTOS	VOLTAJE	CORRIENTE	PESO	FRENTE	FONDO	ALTO
MMF9110	9.5 Pies ³	3	127V/60Hz	1.6A	57 Kg	1.035 m	0.680 m	0.847 m
MMF9113	12.8 Pies ³	4	127V/60Hz	1.6 A	65 Kg	1.275m	0.680 m	0.847 m

• VISTA FRONTAL

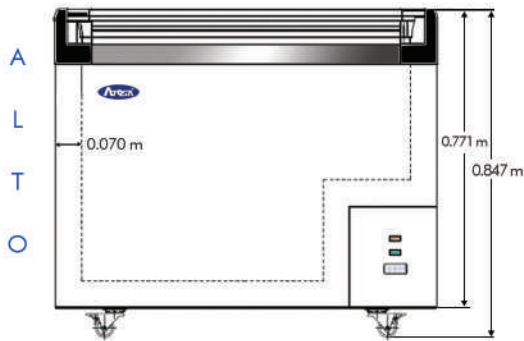

• VISTA TOP

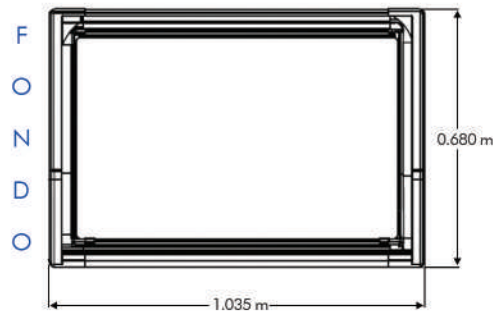

• VISTA LATERAL

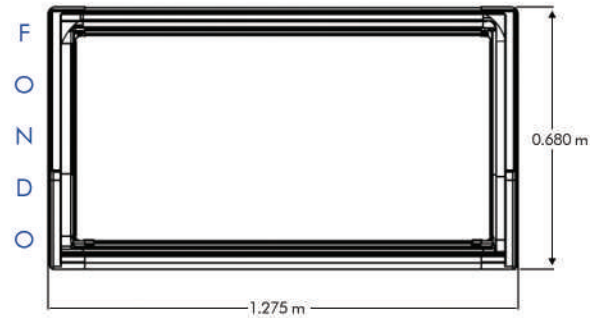
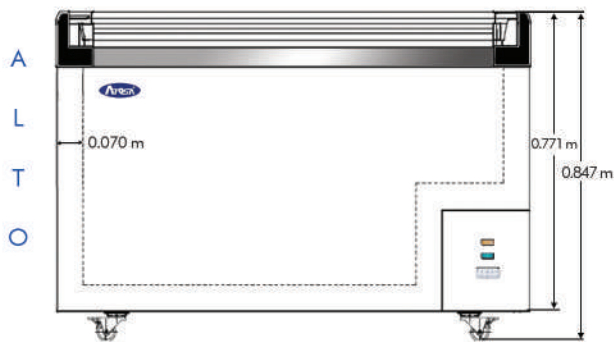
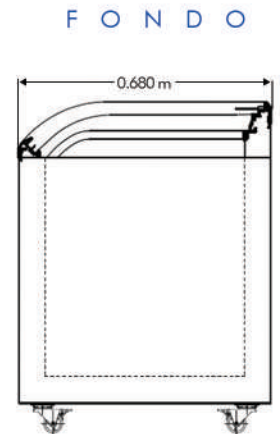

• NOTA: LAS FOTOGRAFÍAS SON ILUSTRATIVAS, EL MODELO ACTUAL PUEDE VARIAR.

• NOTA: EL MEJORAMIENTO DE NUESTROS PRODUCTOS ES FUNDAMENTAL, POR TAL MOTIVO NOS RESERVAMOS EL DERECHO DE INTRODUCIR MODIFICACIONES SIN PREVIO AVISO.