

PROJECT: \_\_\_\_\_

MODEL: \_\_\_\_\_

ITEM #: \_\_\_\_\_ QUANTITY: \_\_\_\_\_

APPROVAL: \_\_\_\_\_ DATE: \_\_\_\_\_

## 3 Gallon Double Bowl Refrigerated Beverage Dispenser

### ITEM NUMBER

#177RDM32

### SPECIAL FEATURES

- Two crystal clear 3 gallon polycarbonate bowls prominently display beverages
- Separate on/off switches for power and stirring paddle
- Manual temperature control from 32-50°F
- Durable stainless steel dispense valve, handle, and cooling cylinder with magnetic drive paddle

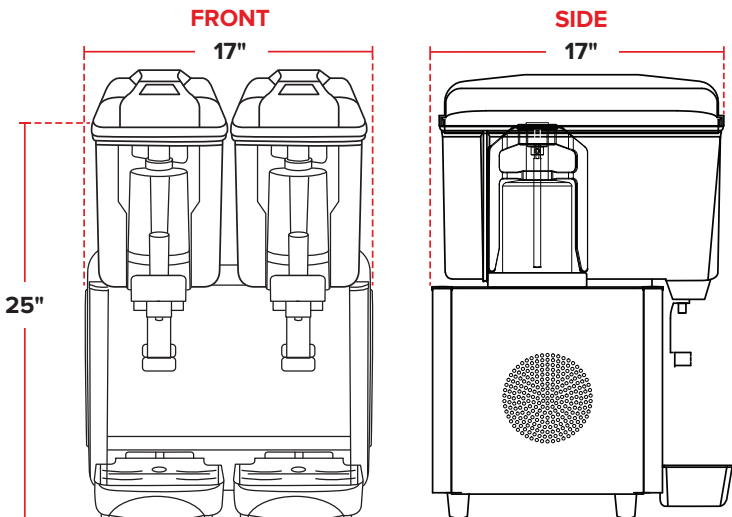

### TECHNICAL DATA

Exterior Dimensions	17" x 17" x 25"
Total Capacity	6 Gallons
Number of Bowls	2
Temperature Range	32-50°F
Voltage	120V
Phase	1



5-15P