

PROJECT: \_\_\_\_\_

MODEL: \_\_\_\_\_

ITEM #: \_\_\_\_\_ QUANTITY: \_\_\_\_\_

APPROVAL: \_\_\_\_\_ DATE: \_\_\_\_\_

## 20 lb. Electric Countertop Fryer

### ITEM NUMBER

#177F102

### SPECIAL FEATURES

- Sturdy stainless steel construction; boasts carrying handles and easy-to-clean removable fry tanks
- Thermostatic controls allow for precise temperature control between 120-370°F
- Uses 3500 watts of frying power total in 2 large 10 lb. capacity tanks
- Fryer basket has front hangers and a coated heat resistant handle for comfortable use
- Night cover and bottom crumb tray included

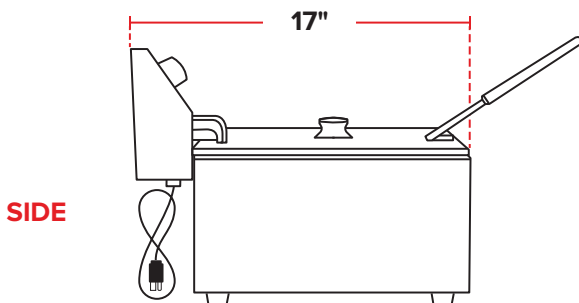
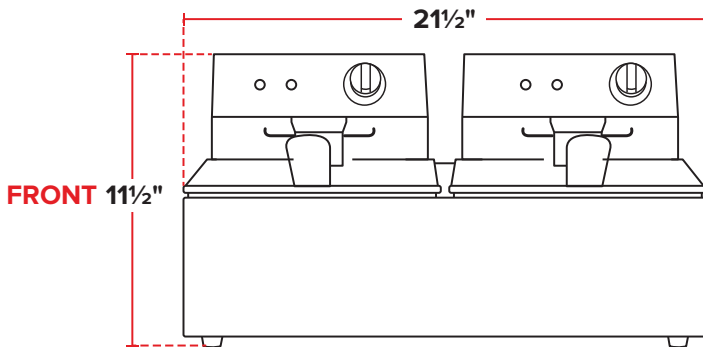

### RECOMMENDED COMPANION PRODUCTS

Item Number	Product Description
147FCBOILOUT	Fryclone Boil-Out Fryer Cleaner

### TECHNICAL DATA

Exterior Dimensions	21 1/2" x 17" x 11 1/2"
Tank/Pot Dimensions	9 1/2" x 12" x 6"
Overall Oil Capacity	20 lb.
Voltage	120V
Wattage	3500W
Amps	29 Amps
Hertz	60
Phase	1

