



WPG250

Large Italian-Style Panini Grill



Large Italian-Style Panini Grill



MAIN FEATURES

- Ribbed, cast-iron plates are great for grilled panini sandwiches, hamburgers, chicken, vegetables and more
- 14.5" x 11" cooking surface has even heat distribution
- Brushed stainless steel body construction and removable drip tray
- Hinged, auto-balancing top plate to suit foods up to 3" thick
- Thermostat is adjustable to 570°F for slow-to-quick cooking times
- Adjustable back feet for efficient grease drainage
- Power ON and READY indicator lights
- Heat-resistant handles; no need for mitts or potholders
- Limited One Year Warranty

ELECTRICAL

Voltage: 120

Frequency: 60Hz

Watts: 1800

Amps: 15

Plug Type: NEMA 5-15P 

Cord Length: 5 feet



SALES FEATURES

Make perfectly grilled panini sandwiches and more with the 120V Waring® WPG250 Large Italian-Style Panini Grill. Grooved, cast-iron plates heat evenly and quickly cook sandwiches, burgers, chicken, and vegetables up to 3" thick. Its brushed stainless steel body and removable drip tray are easy to clean. Includes adjustable thermostat to 570°F along with POWER and READY indicator lights.



@waringcommercial

©2020 Waring Commercial
314 Ella T. Grasso Avenue, Torrington, CT 06790
Tel. 800-492-7464 • Fax 860-496-9008

waringcommercialproducts.com

WPG250



Large Italian-Style Panini Grill WPG250

INCLUDED ACCESSORIES



CAC105 Cleaning Brush

OPTIONAL ACCESSORIES



CAC144 Silicone Spatula
for use with
Nonstick PTFE Sheets



029824 Allen Wrench



035551 Allen Wrench Holder



CAC171 Conversion Kit
with Clips and
3-Pack PTFE Sheets
(3 upper and
3 lower sheets)

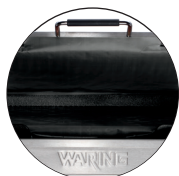

CAC178 3-pack of
Custom PTFE Sheets
(3 upper and
3 lower sheets)

DIMENSIONS

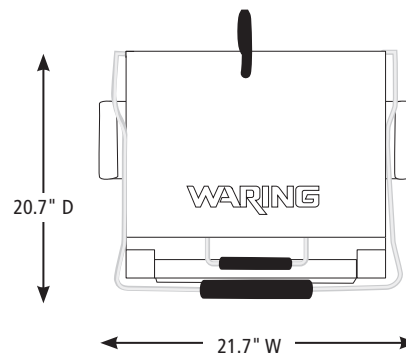
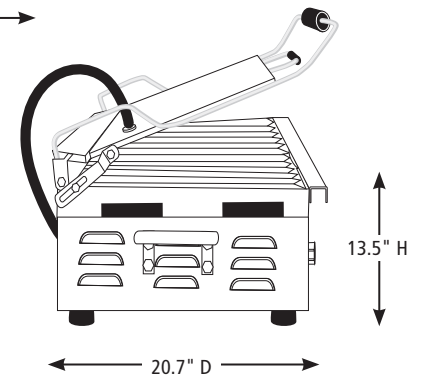
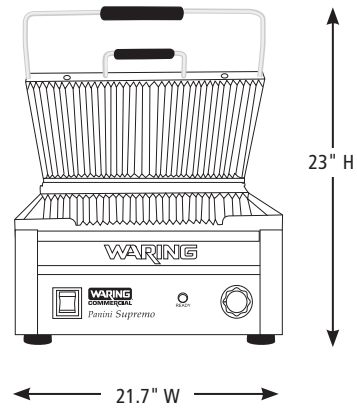

Out of Box Weight: 51.2 lb.

ORDERING INFORMATION	#STD. PKG.	GIFTBOX WEIGHT	CUBIC FEET	BOX DIMENSIONS D X W X H	UPC	CASE PKG.	MC WEIGHT	MC DIMENSIONS D X W X H	MBC
WPG250 – Large Italian-Style Panini Grill	1	73.1	3.61	21.625" x 20.625" x 14"	040072006128	1	75.85	22.5" x 21.5" x 14.625"	10040072006125



@waringcommercial

©2020 Waring Commercial
314 Ella T. Grasso Avenue, Torrington, CT 06790
Tel. 800-492-7464 • Fax 860-496-9008

waringcommercialproducts.com

20WC071642 / REV 06/20