

Item #177GVME12SS

# Vacuum Packaging Machine

with 12" Seal Bar, Roll Cutter & Dual Piston Pump



## Features:

- Durable stainless steel housing is easy to clean and holds up in a busy kitchen environment
- Powerful, maintenance-free dry pump
- Clear vacuum lid so that you can see exactly where you're making your seal
- 3 adjustable vacuum pressures accommodate even delicate foods
- Ability to manually select seal and vacuum time
- Large digital display is easy to read and use
- Housing compartment for holding 11.5"x50' roll with built-in cutter
- Built-in accessory hose for storage canisters
- Includes attachable hose for use with storage canisters

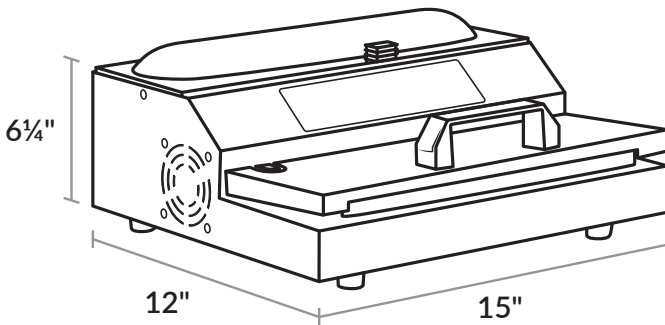

## Specifications:

Width	15"
Depth	12"
Height	6 1/4"
Voltage	120V
Wattage	460W
Number of Seal Bars	1
Seal Bar Length	12"
Seal Wire Width	5 mm
Pump Type	Dry

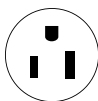

NEMA  
5-15P