

Item #177GVMC10

# Chamber Vacuum Packaging Machine

with 10" Seal Bar & Dry Pump



## Features:

- Stainless steel body for exceptional strength and durability
- Transparent acrylic lid
- Smart Vac Function automatically chooses the best seal time based on the size of the bag
- Marinate function is perfect for prep and sous vide
- Powerful, maintenance-free dry pump
- Intuitive, easy-to-use control panel with digital controls
- Bag-clamp device inside the vacuum chamber allows you to place and fix the bag easily
- Manually adjust vacuum time from 0-80 s and seal time from 0-6 s for ultimate precision
- Compact size minimizes countertop foot print
- Effectively vacuum seals liquid and wet food

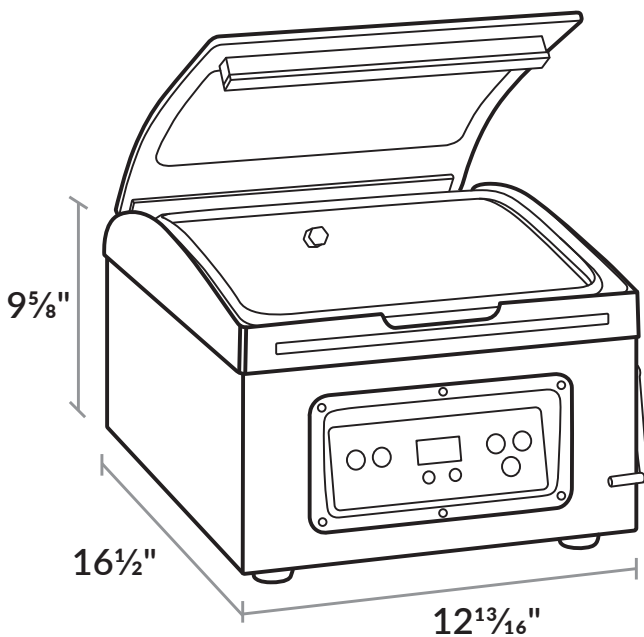

## Specifications:

Width	12 3/16"
Depth	16 1/2"
Height	9 5/8"
Chamber Width	10 7/16"
Chamber Depth	11 13/16"
Chamber Height	3 15/16"
Voltage	120V
Wattage	350W
HP	1/4 HP
Number of Seal Bars	1
Seal Bar Length	10"
Seal Wire Width	2.5 mm
Pump Type	Dry

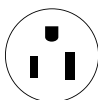

NEMA  
5-15P