

Project _____

Item 186vme1 Quantity _____

Approval _____ Date _____

Galaxy VME1 External Vacuum Packaging Machine with 12" Seal Bar

Item #186VME1

Special Features

- Compact design with large 12" seal bar
- Extended seal time and pulse features seal thick, heavy-duty bags
- Locking lid ensures sealing process remains uninterrupted
- Digital control panel for smooth operation; seal and vacuum & seal options
- Great for extended storage or sous-vide cooking

Technical Data

| | |
|--------------------------------------|--------------------------------------|
| Width | 15 Inches |
| Depth | 6 5/8 Inches |
| Height | 2 15/16 Inches |
| Seal Bar Length | 12 Inches |
| Seal Wire Width | 2 Millimeters |
| Hertz | 60 Hertz |
| Phase | 1 Phase |
| Voltage | 120 Volts |
| Wattage | 100 Watts |
| Features | Pulse Option Vacuum Canister Port |
| Number of Seal Bars | 1 |
| Plug Type | NEMA 1-15P |
| Power Type | Electric |
| Style | External Strip |
| Vacuum Packaging Machine Type | Automatic |



Certifications



Technical Drawing

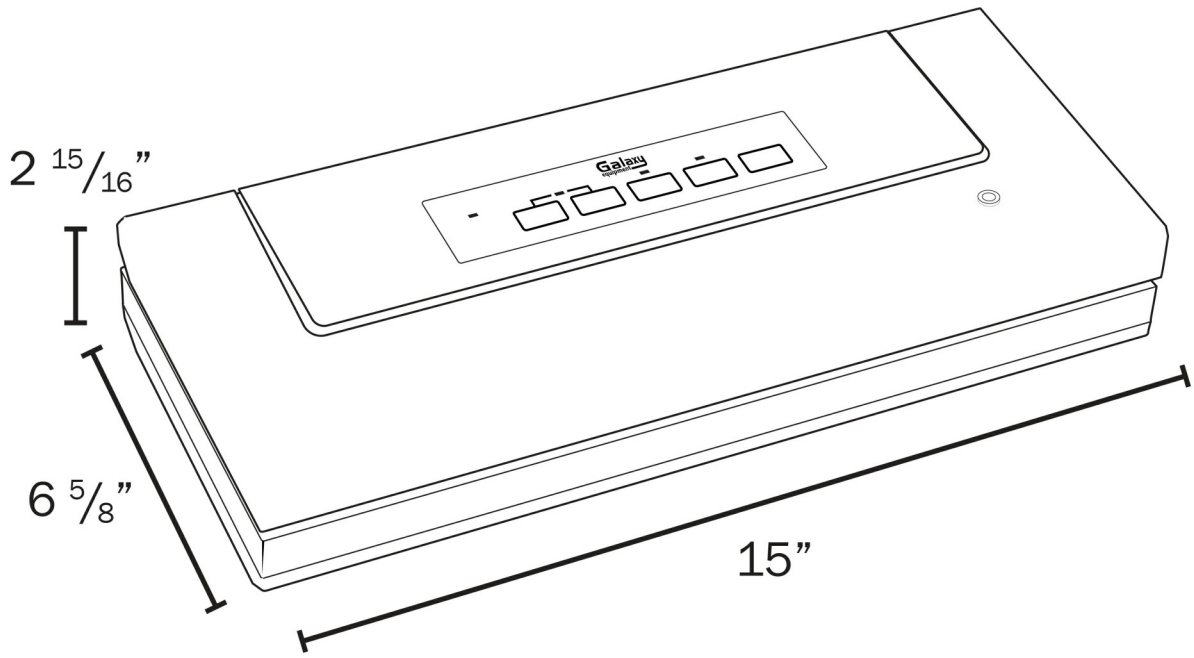

⚠ WARNING: This product can expose you to chemicals including lead, which are known to the State of California to cause cancer, birth defects, or other reproductive harm. For more information, go to www.p65warnings.ca.gov.