



# WDM240TX

## Heavy-Duty, Double-Spindle Drink Mixer with Timer



Heavy-Duty, Double-Spindle Drink Mixer with Timer



### MAIN FEATURES

- Two independent, high-performance, 1 peak HP motors are user-replaceable for continued operation
- Each motor includes thermal protection to prolong motor life
- Electronic, 3-speed and pulse controls maintain speed under load for optimal performance – 15,000 / 18,000 / 21,000 RPM
- Fully enclosed actuators prevent mix from entering the housing
- Each unit includes 2 agitators for each spindle: One solid agitator for mixing hard ice creams and aerating for increased yield, and one butterfly agitator for softer ice creams and mix-ins
- Increased cup clearance: Slide cups into position without tilt
- Fully automatic, cup-activated, one-handed START/STOP operation
- 10-minute timers
- Heavy-duty, powder-coated die-cast steel housing
- Two stainless steel malt beverage cups included
- Limited One-Year Warranty

### ELECTRICAL

Voltage: 120  
 Frequency: 50/60Hz  
 Watts: 750  
 Amps: 2.2  
 Plug Type: NEMA 5-15P ⓘ  
 Cord Length: 5 feet



### SALES FEATURES

Mix perfect drinks, one or two at a time, with the Waring® WDM240TX Heavy-Duty Double-Spindle Drink Mixer with Timer. Automatic shutoff lets you attend to other tasks, while two independent, 1 peak HP motors and ultra-aggressive agitators power through the coldest, hardest ice creams. Increased cup clearance helps you avoid spills while making creamy milkshakes and malts your customers will love.



@waringcommercial

©2019 Waring Commercial  
 314 Ella T. Grasso Avenue, Torrington, CT 06790  
 Tel. 800-492-7464 • Fax 860-496-9008

waringcommercialproducts.com

WDM240TX



# Heavy-Duty, Double-Spindle Drink Mixer with Timer WDM240TX

## INCLUDED ACCESSORIES



**CAC20** Stainless Steel Malt Cup



**CAC112** Solid Agitator (6 pack)



**CAC123** Butterfly Agitator (6 pack)

## DIMENSIONS

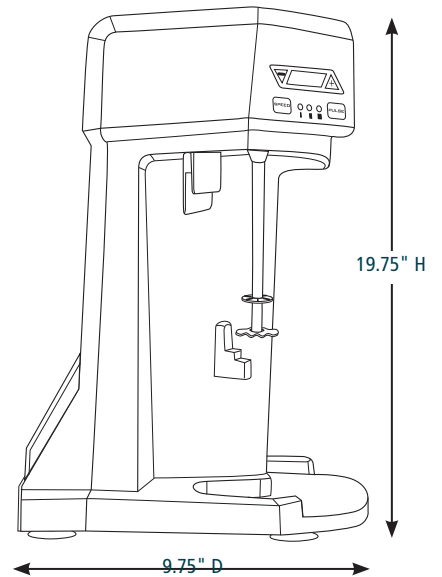
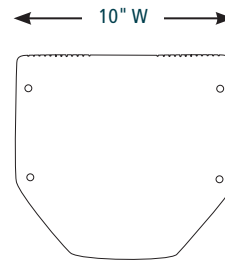
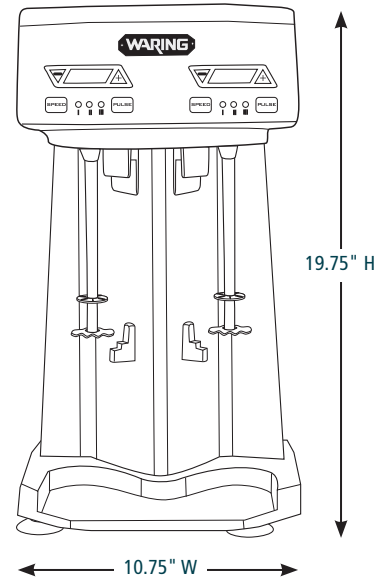

Out of Box Weight: 24.5 lb.

ORDERING INFORMATION	#STD. PKG.	GIFTBOX WEIGHT	CUBIC FEET	BOX DIMENSIONS L X W X H	UPC	CASE PKG.	MC WEIGHT	MC DIMENSIONS L X W X H	MBC
WDM240TX – Heavy-Duty, Double-Spindle Drink Mixer with Timer	1	28.49	1.9	13.1" x 11.9" x 22"	040072083297	1	29.7	13.8" x 13.6" x 22.8"	10040072083294



@waringcommercial

©2019 Waring Commercial  
314 Ella T. Grasso Avenue, Torrington, CT 06790  
Tel. 800-492-7464 • Fax 860-496-9008

waringcommercialproducts.com

19WC059595 / REV 08/19