



36" Self Service, 3 Shelf Heated Display Warmer with Sliding Doors

ITEM NUMBER

#177HDC36

SPECIAL FEATURES

- Front and rear sliding doors for convenient self service and easy refilling by staff
- Thermostatic temperature controls adjust from 85-185°F
- Fast pre-heat time; reaches 120°F in 10 minutes
- Durable stainless steel body and racks with a sleek black finish
- Independent light switch; 2 interior lamps to illuminate wrapped food

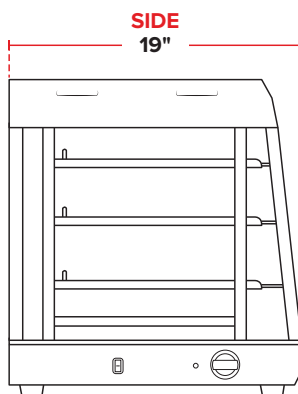
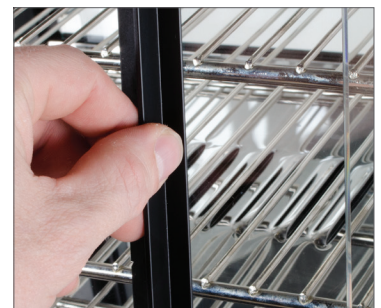
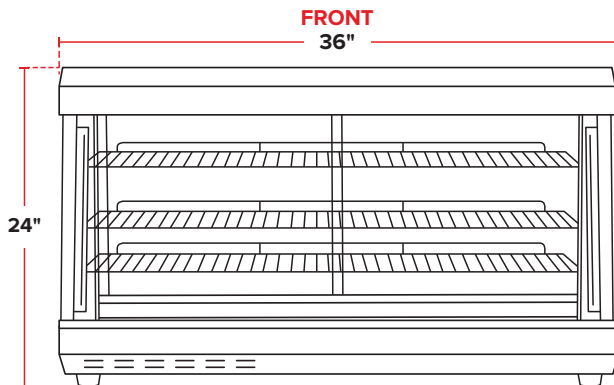

TECHNICAL DATA

Dimensions	36" x 19" x 24"
Number of Shelves	3
Amps	13.6
Hertz	60
Voltage	110V
Wattage	1500W
Control Type	Thermostatic
Installation Type	Countertop

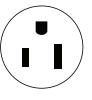

5-15P